



MORE POWER : LESS NOISE



Shown with optional Fishtail tip Part # 16923

Congratulations, you have purchased the finest exhaust system for your motorcycle on the market. Your Vance & Hines exhaust system is designed and crafted for maximum performance, a perfect fit, a great sound and unbeatable style. Please follow the installation instructions below and if you have any questions, please call our technical support line at (562) 926-5291.

Attention installer (if other than owner), please forward this instruction sheet to the owner of this product. These instructions contain valuable information to the end user.

**TOOLS
REQUIRED**

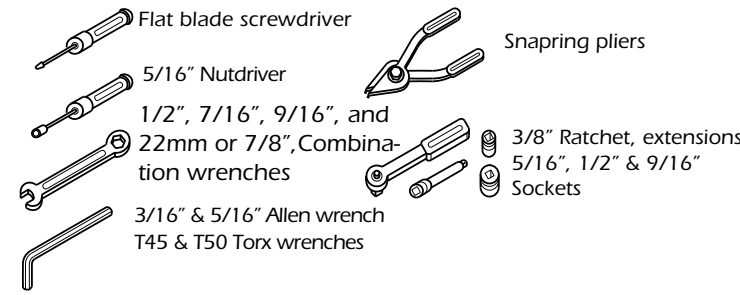

READ ALL INSTRUCTIONS BEFORE BEGINNING INSTALLATION

**STOCK EXHAUST
SYSTEM REMOVAL**

NOTE: These instructions are written for 2007 and newer models; ignore any O2 sensor instructions for 1997-2006 models. 1997-2006 models will require #16925 Sensor Plug Kit.

1. Under the oil tank on the right hand side, locate the rear oxygen sensor connector. Unplug sensor and feed the end of wire through the frame freeing it from motorcycle. NOTE: Pay attention to wire routing for re-installation.
2. Open the plastic cover above the rectifier on front of the frame to gain access to the front oxygen sensor connector. Unplug sensor from harness. Remove cable tie holding wire to frame and feed the end of the wire through freeing it from motorcycle.
3. On FLSTC, FLSTF, FLSTN and FLSTSC models, loosen the right hand floor board mounting bolts to gain clearance for exhaust removal and installation.
4. Loosen the heat shield clamps on both front and rear exhaust pipes.
5. Remove the two mounting nuts from each head pipe, located at the cylinder head.

6. Remove the nuts attaching the exhaust mount bracket to the frame.
7. On FLSTN, FLSTF and FXSTD models, you will need to remove the right side passenger footpeg and hanger, as this is attached to the exhaust mount bracket. Replace the passenger foot peg assembly using the 3/8" x 2 1/2" Allen bolt (supplied).
8. If equipped, unbolt the carriage bolt and clamp attached to the bracket under the right side transmission cover.
9. Remove the entire exhaust system and set it aside.
10. If equipped, remove the bracket from under the right side transmission cover.
11. Using a 7/8" or 22mm wrench, carefully remove the O2 sensors from the stock head pipes and save for re-use with the new system.
12. Remove the two lower mounting studs from the frame (Figure 1).
13. Carefully remove exhaust port flanges and circlips from the stock exhaust system using snapping pliers. NOTE: Replace bent or damaged circlips. Check exhaust port gasket condition. Recommended replacement exhaust port gaskets, Harley part number:17048-98 or 65324-83A.

FIGURE 1

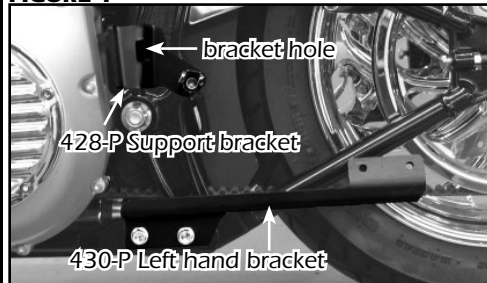

FIGURE 2

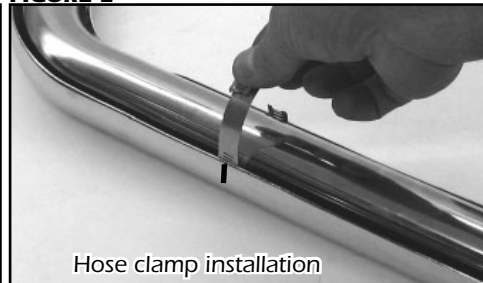

FIGURE 3

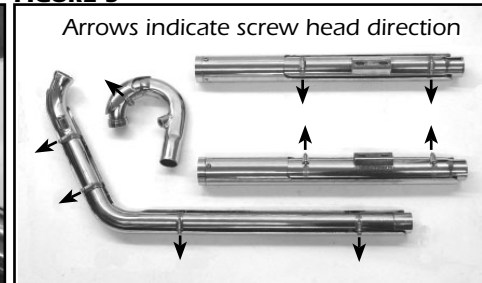

FIGURE 4



FIGURE 5

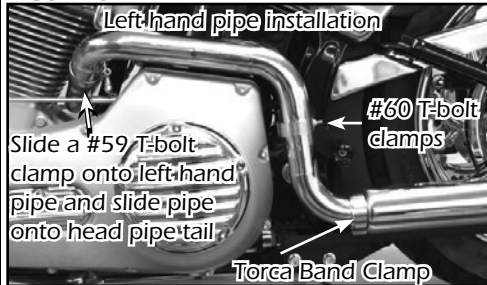

FIGURE 6

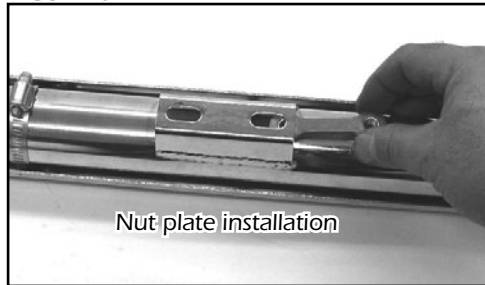

FIGURE 7



FIGURE 8



- Attach mounting brackets 430-P on the left side and 431-P on the right side of the frame using two 3/8" x 3/4" flange head bolts on each one (supplied)(Figure 1). If equipped, plastic plugs must be removed.
- Remove left foot peg and attach support bracket 428-P (Figure 1) using the stock bolt. Discard spacer if equipped. Do not tighten at this time. NOTE: On FLSTN models the passenger footpeg bracket should be removed.
- Remove head pipes and heat shields from protective packaging. Place each heat shield on a non-abrasive surface such as a blanket or carpet. Using a felt tip pen, mark outside edge of each heat shield to show location of mounting clips that hose clamps will loop through (Figure 2).
- Lay front head pipe, rear head pipe and mufflers into their heat shields.
- Install #20 hose clamps on heat shields and #28 on muffler heat shields by feeding tail end of clamps into heat shield clips (Figure 2). Install D486HC heat shield by using only one hose clamp, feeding tail clamp through the bigger clip. Take note of clamp screw head direction (Figure 3). Screw heads must be accessible when system is installed on motorcycle for adjustment purposes. NOTE: Do not tighten at this time.
- Install exhaust port flanges and circlips from stock system onto head pipes (Figure 4).
- Apply a small amount of anti-seize compound to the threads of one of the oxygen sensors and install it into front head pipe. NOTE: Be careful not to get anti-seize on sensor tip, it may affect sensor function. Do not install rear sensor at this time.
- Disconnect front mount on shift lever rod to allow installation of rear head pipe (Figure 7).
- Using stock flange nuts, carefully install head pipes into exhaust ports. Assistance may be required. NOTE: Do not tighten at this time.
- Remove ignition coil cover to have open access to install rear sensor.
- Install rear sensor using same instructions as step 7. Feed connector for rear oxygen sensor through frame and under the oil tank. Plug the sensor into stock wiring connector.
- Slide a #59 T-bolt clamp (supplied) onto slotted end of left pipe. Slide slotted end onto head pipe tail (Figure 5). Align pipe with bracket 428-P previously installed in step 2. Install a #60 T-bolt clamp (supplied) by removing the nut and feeding the tail end through bracket hole (Figures 1 and 5). NOTE: Orient the clamp so that you can get to the nut after installation. Do not tighten at this time.
- Slide a Torca band clamp (supplied) onto the nose of each muffler body (figure 5). NOTE: Orient the clamps so that you can access the nut after installation.
- Install right and left mufflers onto tail end of right head pipe and left pipe. Slide nut plate (supplied) inside bracket that is welded to backside of muffler (Figure 6). Loosely install two 5/16" x 5/8" flange head bolts (supplied). Align mufflers with their brackets so they sit level. Tighten the muffler mounting bolts then the bracket mounting bolts.
- Tighten rear exhaust port flange nuts. NOTE: Be sure to center head pipe between head fins and frame bar, Also make sure that there is sufficient clearance to the oil lines (Figure 7). Tighten T-bolt clamp on the header. Tighten cylinder port exhaust flange nuts on front cylinder.
- Tighten bracket 428-P and T-bolt clamp attached to this bracket, making sure that left pipe is aligned to bracket.
- Lay left pipe heat shield on left hand pipe and install #20 hose clamps. Take note of clamp screw head direction (Figure 8).
- Tighten all Torca band clamps, T-bolt clamps and all heat shield clamps.
- Reinstall and tighten ignition coil cover and front mount on shift rod.
- Feed wire for the front oxygen sensor through the frame and into the plastic holder on the frame. Plug the sensor into the stock wiring connector. Snap the plastic holder closed to hold the connector in place.
- Install a new nylon cable tie (supplied) to hold the wires onto the frame in the original location.
- Tighten the floor board mounting bolts on models so equipped.
- Check for adequate clearance of all exhaust system components and motorcycle accessories prone to heat damage.
- Be sure to tighten all hardware before starting your motorcycle.
- After installation and before starting motorcycle, completely clean pipes and mufflers with cleaning solvent and a clean, soft cloth that will not leave a residue. NOTE: Any residue, oil, or fingerprints will stain the chrome when the metal heats up.

EXHAUST CARE - HELPFUL HINTS TO AVOID DISCOLORATION OF EXHAUST SYSTEM

- When installing a new set of chrome pipes, make sure your hands are clean and free of oil. After installation, thoroughly clean pipes with a soft cloth and cleaning solvent that will leave no residue (chrome wax / polish, glass cleaner, alcohol, ammonia, etc...) before starting the motorcycle.
- Avoid long periods of idling as this can cause discoloration.
- Intake leaks can cause the engine to run lean and overheat, this could lead to discoloration.
- Make sure there are no exhaust leaks at the junction of the exhaust pipes and cylinder head. We recommend replacing gaskets if they are worn.

VANCE & HINES OPTIONAL ACCESSORIES

FUELPAK



FUEL MANAGEMENT:
Take the guess work out of fuel injection with Fuelpak Fuel Management. Contact your local dealer or call (562) 921-0071 to order. Visit fuelpakfi.com for more information. Fuelpak is intended for racing or off-highway use only, and is not legal for sale or use in California on pollution-controlled vehicles.

- | | |
|-----------|--|
| P/N 16925 | O2 Sensor Plug Kit f/ 1997 thru 2006 models. |
| P/N 71005 | Naked Air Filter Assembly |
| P/N 71015 | Black Ceramic Skullcap Intake Cover |
| P/N 71013 | Chrome Skullcap Intake Cover |
| P/N 21869 | Quiet Baffle. The quiet baffle will lower the sound level by 2-3db on average. Contact your local dealer to order. |

PLEASE NOTE: Every effort is made for Vance & Hines Exhaust Systems to provide improved cornering clearance. However, due to design and space limitations on some motorcycle models, ground and cornering clearance may not be improved and in some cases may be reduced. Be sure to follow proper installation instructions.



MORE POWER : LESS NOISE

ALL PARTS SHOWN ARE ACTUAL SIZE

PACKING LIST

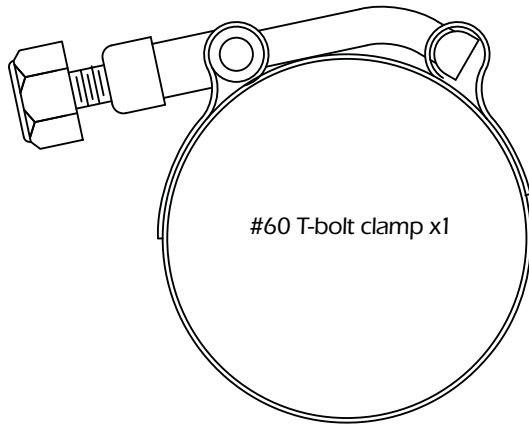

#60 T-bolt clamp x1

#28 Hose clamp x 4

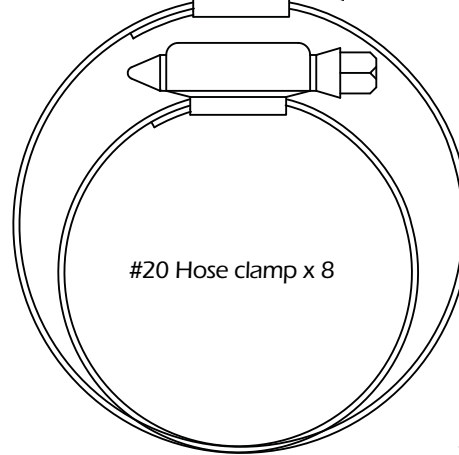
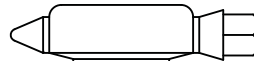

#20 Hose clamp x 8

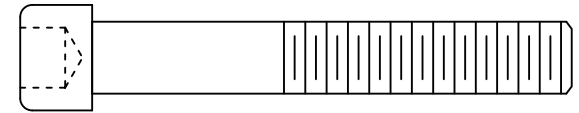

3/8" x 2 1/2" Allen bolt x1

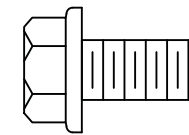

5/16" x 5/8" Flange head bolt x4

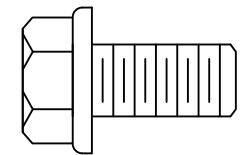

3/8" x 3/4" Flange head bolt x4

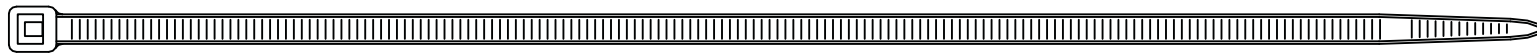

Nylon cable tie x1

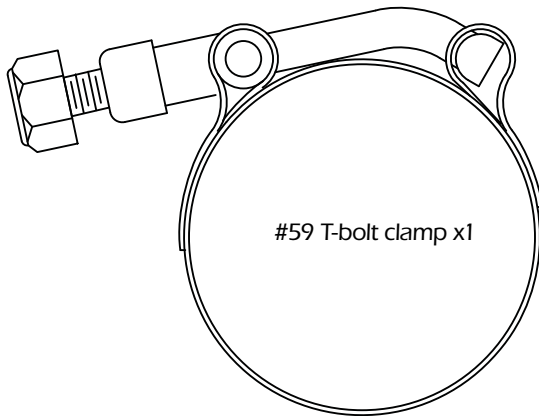

#59 T-bolt clamp x1

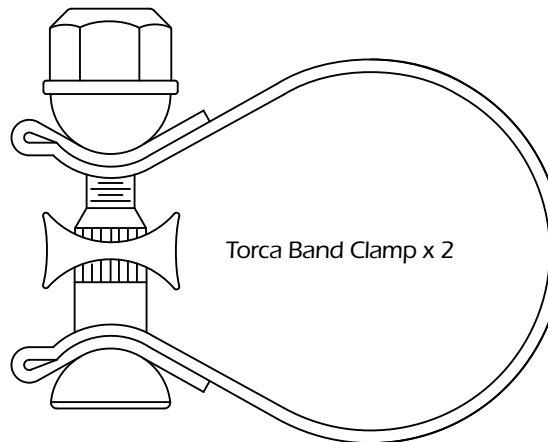

Torca Band Clamp x 2

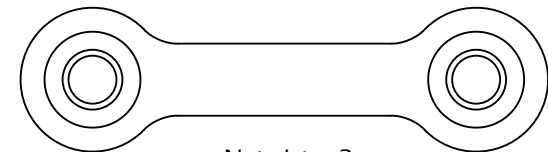

Nut plate x2

PARTS NOT SHOWN:

- D485FC Front head pipe x1
- D486FC Rear head pipe x1
- D489FC Rear left hand pipe x1
- D485RC Muffler x2
- D485HC Front heat shield x1
- D486HC Rear header heat shield x1
- D488HC Rear left hand heat shield x1
- D700HC Right hand muffler heat shield x1
- D701HC Left hand muffler heat shield x1
- 428-P Left hand support bracket x1
- 430-P Bracket x1
- 431-P Bracket x1

WARRANTY

Vance & Hines exhaust systems are warranted against defects in material and workmanship for a period of 90 days from the date of purchase from an authorized dealer. This warranty does not cover discoloration of chrome finishes. This warranty is limited to the repair or replacement of a product proven to be defective from normal use. Vance & Hines exhaust systems are designed to fit and operate on OEM motor and chassis. This warranty does not cover any product subject to abuse, misuse, improper installation or modification.

FUEL MANAGEMENT

GET THE MOST OUT OF YOUR RIDING EXPERIENCE...

AN AFTERMARKET EXHAUST SYSTEM IS ONLY YOUR FIRST STEP, NOW YOU NEED FUEL MANAGEMENT.

NOW YOU NEED FUELPAK.

Your fuel injected Harley-Davidson® is equipped with an ECU (electronic control unit) that's programmed to deliver fuel to the motor based on an air/fuel ratio for a stock air filter and stock exhaust system. When you install a performance exhaust system, your airflow changes, so you need a fuel management system that adjusts your air/fuel ratio to match the changes. That fuel management system is Fuelpak. Fuelpak adds and takes away fuel, allowing for a more precise range of refinement in your air/fuel ratio. Get the perfect fuel management combination with your Vance & Hines exhaust system, get Fuelpak. For more information visit the tuning center at vanceandhines.com/fuelpak.

NOTICE: Fuelpak is intended for racing or off-highway use only, and is not legal for sale or use in California on pollution-controlled vehicles.

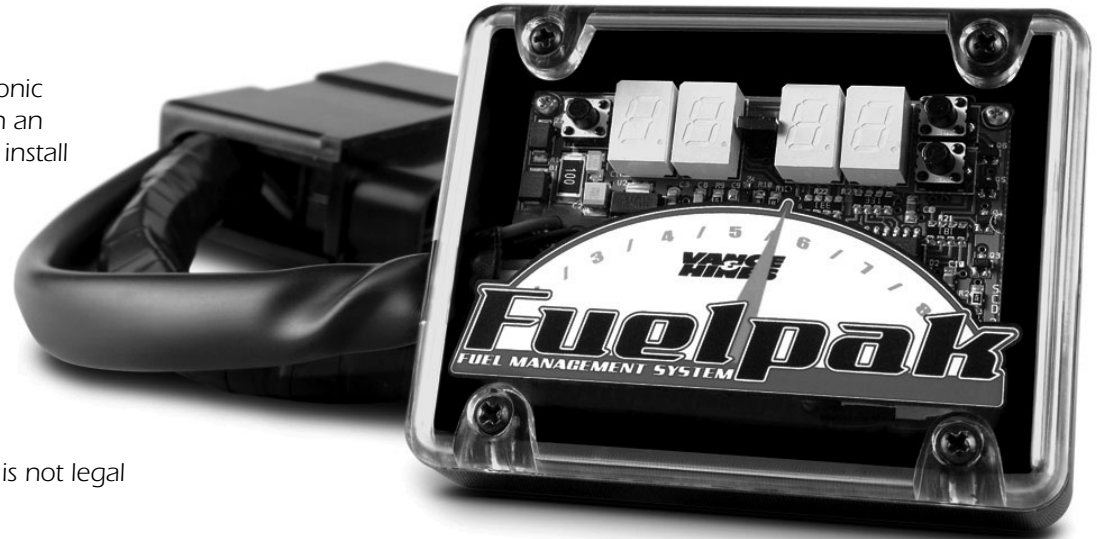

OPTIONAL TIPS



For even more style, customize your exhaust system with the Billet Slash-cut end tips.



Fishtail end tips are 100% designed and manufactured by Vance & Hines and include the same level of quality and performance as our exhaust systems.

13861 ROSECRANS AVENUE / SANTA FE SPRINGS, CA 90670
SALES: (562) 921-7461 / TECHNICAL: (562) 926-5291 / FAX: (562) 802-0110
VANCEANDHINES.COM

MORE POWER : LESS NOISE

BILLET SLASH-CUT TIPS - 16921

FISHTAIL TIPS - 16923